

# HEAVY DUTY Pipe wrenches

The Heavy Duty wrenches from EGA Master are specially designed for the most demanding industrial applications such as mining, oil, aerospace and automotive industries.



Made of accurate  
ductile casting APC

UNLIMITED GUARANTEE

1. Full floating forged hook jaw for **fast ratcheting action**.

2. **Graduations** on hook jaw show approximate size of opening for different pipe sizes.



3. Replaceable, **twice hardened alloy steel jaws**. Precision-milled, biased tooth design maximizes gripping strength and tool life.

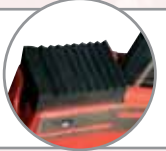

4. Riveted jaw.



5. **Knurled adjustment nut** for easy one-handed operation.

6. Large flange prevents nut from being inadvertently rotated when wrench is set down.

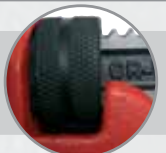

7. Extra large self-cleaning threads.



8. Ductile casting APC I-Beam handle with **maximum strength and minimal weight**, which exceeds in 180% the federal GGG-W-651-E Type II Class A standard requirements.

9. Wide gripping surface for **increased comfort**.

10. Month and year of manufacturing laser engraved on the tool for proper traceability.

11. Convenient hanging hole for **easy storage**. Enlarged handle end helps prevent slippage.

### HEAVY DUTY PIPE WRENCH

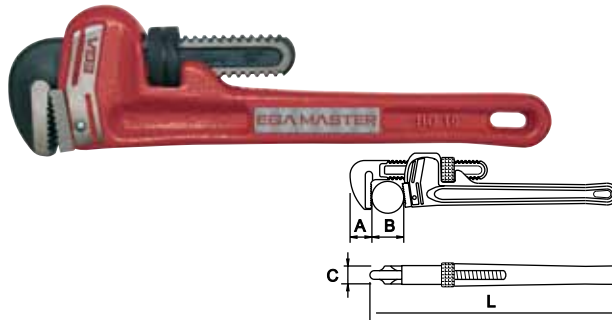

COD	L	A	B	C	Kg		
61299*	6"	13	3/4"	11	0,2	6	1
61014	8"	15	1"	14	0,4		
61015	10"	20	1.1/2"	17	0,8		
61016	12"	23	2"	20	1,3		
61017	14"	25	2"	23	1,7	3	
61018	18"	28	2.1/2"	26	2,6		
61019	24"	33	3"	29	4,5	1	-
61020*	36"	43	5"	33	9,5		
61021*	48"	55	6"	35	14		
61045*	60"	85	8"	41	20		

\*Nodular ductile casting GGG-W-651-E, Type II Class A

### SPARE PARTS Heavy duty & Aluminium Heavy duty

- Spring set
- Nut
- Heel jaw
- Hook jaw

6"	85085	85083	85084	85082
8"	81022	81015	81008	81001
10"	81023	81016	81009	81002
12"	81024	81017	81010	81003
14"	81025	81018	81011	81004
18"	81026	81019	81012	81005
24"	81027	81020	81013	81006
36"	81028	81021	81014	81007
48"	81031	81030	81029	81000
60"	81674	81672	81673	81671

### OFFSET HEAVY DUTY PIPE WRENCH

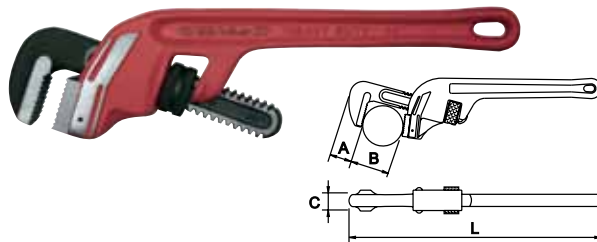

COD	L	A	B	C	Kg		
61029*	8"	16	1"	20	0,35	6	1
61030*	10"	20	1.1/2"	23	0,80		
61031*	12"	22	2"	26	1,30		
61032*	14"	25	2"	29	1,54		
61033*	18"	27	2.1/2"	33	2,30	3	-
61034*	24"	31	3"	35	4		

\*Nodular ductile casting GGG-W-651-E, Type IV

### OFFSET PIPE WRENCH 90°

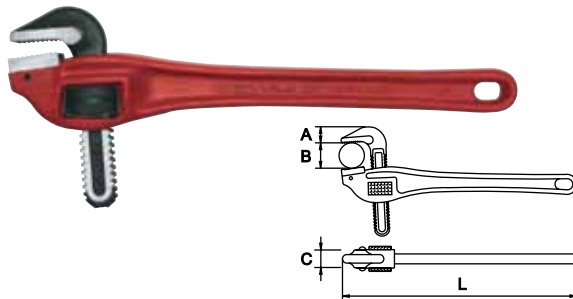

COD	L	A	B	C	Kg		
61377*	14"	25	2"	23	1,60	2	1
61378*	18"	29	2.1/2"	26	2,70	1	-

\*Nodular ductile casting GGG-W-651-E, Type II Class A

## TECHNICAL SPECIFICATIONS

MATERIAL	Handle	Ductile cast iron (nodular)
	Heel jaw	Steel alloy
	Movable jaw	Cr-V
HARDNESS	Handle	120-160Hb
	Heel jaw	55-60 HRC
	Teeth of the movable jaw	55-60 HRC
FINISHING	Handle	Painted in Epoxy powder red color ral-2002 semi-texturized
	Heel & Movable jaw	Black finished

# HEAVY DUTY Aluminium



1. They are composed of **TITALUM®** special aluminium alloy, which makes the wrench **up to 50% lighter**.

2. TITALUM® alloy **provides extra resistance, exceeding the strictest standard GGG-W-651 E, Type II Class C** by more than 30%.

3. Electro Epoxy Powder painting for additional **resistance to shock and friction**.

4. **Month and year of manufacturing laser engraved** on the tool for proper traceability.

## ALUMINIUM PIPE WRENCH

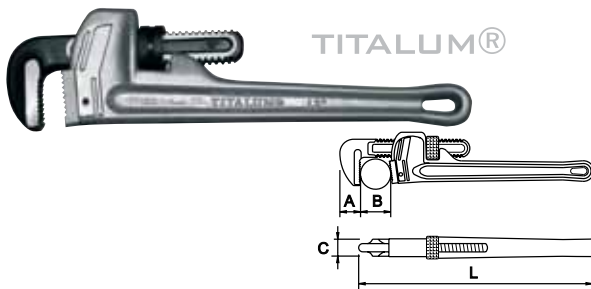

TITALUM®

COD	L	A	B	C	Kg		
61044	10"	20	1.1/2"	17	0,5		
61023	12"	23	2"	20	0,8	6	1
61024	14"	25	2"	23	0,9	3	
61025	18"	28	2.1/2"	26	1,6		
61026	24"	33	3"	29	2,5		
61027	36"	43	5"	33	5,0	1	-
61028	48"	55	6"	35	7,5		

GGG-W-651-E, Type II Class C

## ALUMINIUM OFFSET PIPE WRENCH 90°

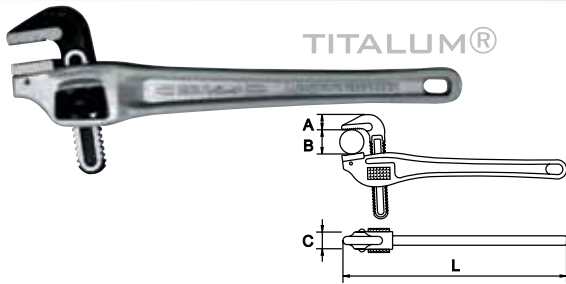

TITALUM®

COD	L	A	B	C	Kg		
61363	14"	25	2"	28	0,8	6	1
61364	18"	28	2.1/2"	39	1,2	2	
61365	24"	34	3"	42	2,2	1	-

GGG-W-651-E, Type II Class C

# TECHNICAL SPECIFICATIONS

MATERIAL	Handle	Cast aluminium alloy titalum®
	Heel jaw	Steel alloy
	Movable jaw	Forged steel
HARDNESS	Handle	100-110Hb
	Heel jaw	55-60 HRC
	Teeth of the movable jaw	55-60 HRC
FINISHING	Handle	Painted in grey color with metal powder semi-texturized
	Heel & Movable jaw	Black finished